

INTEGRA HEATER INSTALLATION MANUAL

1. Description

The INTEGRA heater is designed for accumulating heat generated by such sources as: a solid fuel burner, a fireplace, a heat pump and solar collectors. Heat from a natural gas, oil or electric boiler, or an electric heater designed to heat up utility water can also be supplied to the reservoir. The large number of connection stubs makes the reservoir work perfectly as a hydraulic coupling.

Among the heaters of this type which are available in the market, INTEGRA is distinctive for its design which ensures a clear, three-zone division of its internal capacity. The upper zone is destined to heat up utility water, the middle zone to feed the central heating system while the lower one is designed for solar collectors as well as for accumulating heat from such sources as a heat pump, a fireplace or a solid fuel burner. A significant advantage of the device is its inner design which prevents water from getting mixed as a result of the dynamics of supply streams and collection processes by devices connected to the reservoir. Specially made baffle plates make it possible, for example, that a natural gas condensation boiler reduces its operational temperature after a period of working at a high parameter of 70°C down to a parameter of 30°C, required for floor heating. This also improves the efficiency of the boiler. Inside, along the entire height of the heater, an enamelled warm water reservoir is installed. Cold water which flows in from the bottom is first heated by the solar energy and then reheated from other sources of heat. It certainly improves the efficiency of the solar collector energy use, allowing the solar collectors to work at a lower parameter. The lower cold water supply also makes it convenient to empty and clean the inner heater. The heater is equipped with an internal detachable soft 100 mm thick insulation.

INTEGRA heater design

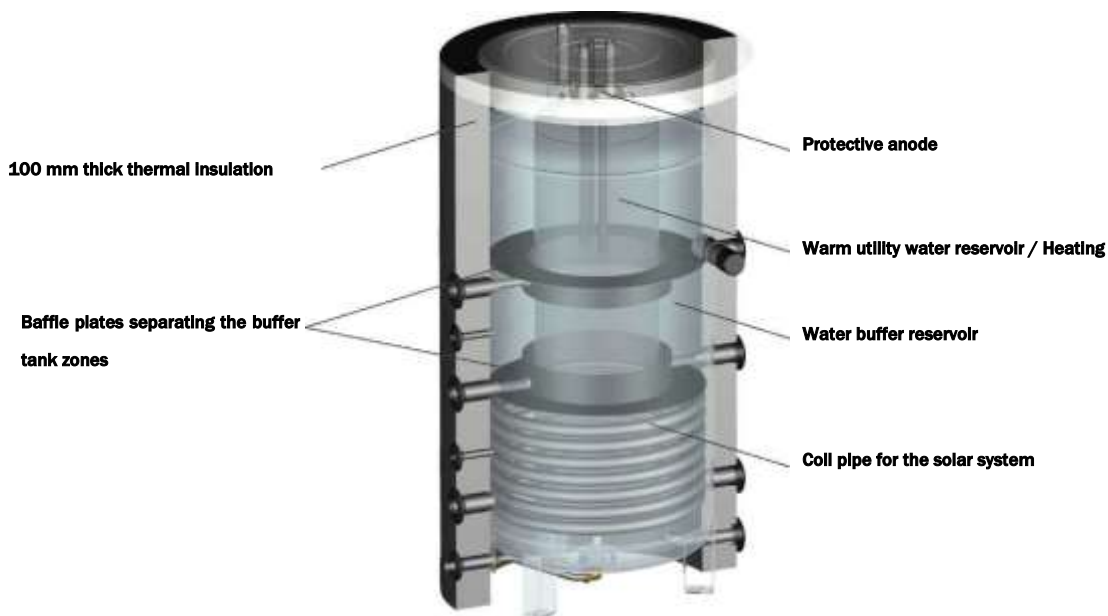

2. Technical Specifications

Table 1.

Specification / Type	INTEGRA 400/100	INTEGRA 500/120	INTEGRA 800/200
Total capacity	330 l	480 l	800 l
Warm utility water reservoir	100 l	120 l	200 l
Maximum pressure in the heating water reservoir	3 bar	3 bar	3 bar
Maximum pressure in the utility water reservoir	6 bar	6 bar	6 bar
Maximum operational pressure	90°C	90°C	90°C
Tubular heat exchanger surface area	1.3 m ²	1.5 m ²	2.2 m ²
Maximum surface area of the solar collector absorber for the tubular exchanger	8 m ²	10 m ²	14 m ²
Thermal insulation thickness	100 mm	100 mm	100 mm
Total height	1480 mm	1850 mm	2015 mm
Diameter without insulation /with insulation	600/800 mm	650/850 mm	790/990 mm
Weight	130 kg	158 kg	210 kg

3. Arrangement and Description of Connection Stubs

Stub arrangement drawing

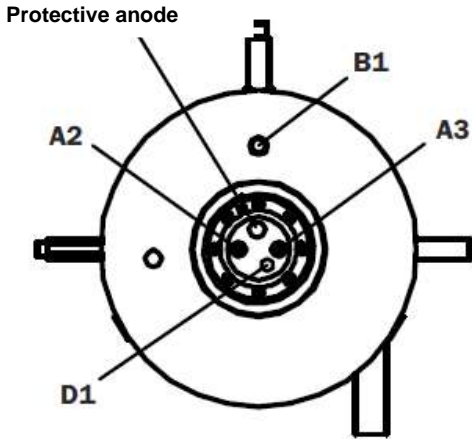

Top view

Descriptions of stubs:

A - stubs on the utility water side

- A1 - Gz3/4" - cold water supply
- A2 - Gz3/4" - warm water collection
- A3 - Gz3/4" - return from circulation

B - stubs on the heating water side

- B1 - Gz1" - air vent
- B2 - Gz1 1/2" - electric heater stub
- B3 to B10 - Gz1" - connection stubs for supply and return flows (see the description of solutions for details)
- B11 - Gz1" - fill-in stub for the heating water

C - stubs of the tubular heat exchanger (solar collectors, other external source of heat)

- C1 - Gz1" - power supply from solar collectors
- C2 - Gz1" - return to solar collectors

D - bushings of temperature sensors - internal diameter: 11 mm

- D1 - for the heater upper zone
- D2 - for the heater middle zone
- D3 - for the heater lower zone

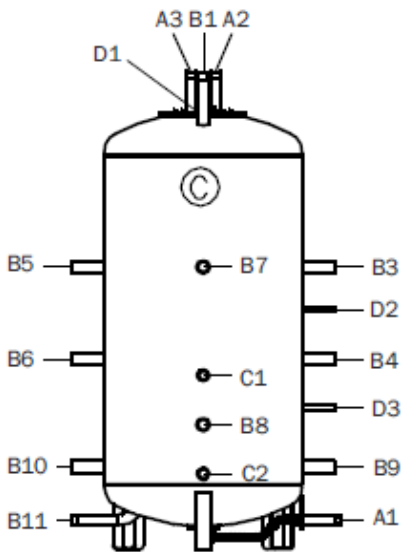

Rear view (C)

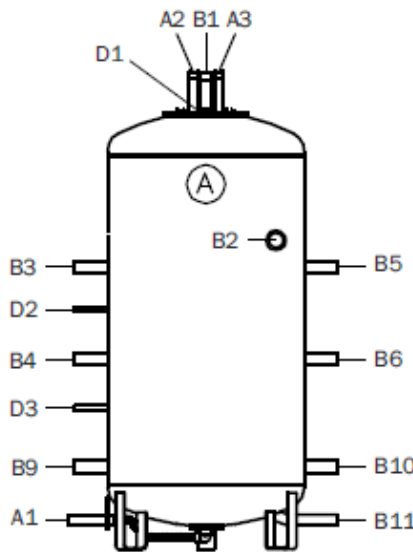

Front view (A)

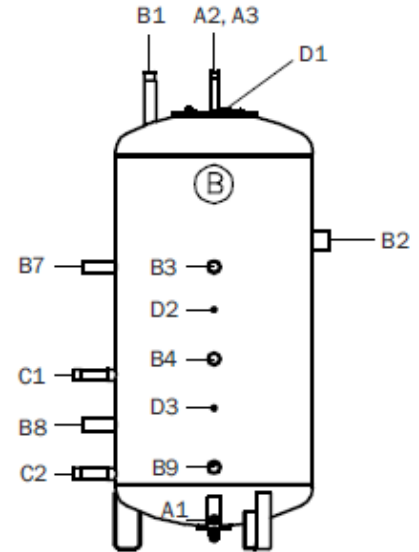

Side view right side (B)

4. Heater Choice and Installation

The heater capacity should be chosen in relation to the actual level of demand for warm utility water, power of heat sources, demand for accumulated heat on the collection side as well as the surface area of the installed solar collectors. A detailed choice can be made by the system designer.

Both the internal reservoir for the utility water and the external reservoir for the heating water must be secured with safety valves with the maximum opening pressure of 6 bar for the warm utility water and 3 bar for the heating water respectively.

NOTE!!! First, fill up the internal warm utility water reservoir with water and keep it the operational pressure inside it; secondly fill up the reservoir with the heating water. If you reverse the filling sequence, the internal reservoir can become damaged in a way which is not covered by the given warranty.

Install the separately provided insulation before beginning to install the connections to the reservoir.

5. Diagrams of the INTEGRA Heater Connections to the System

Since there are many possibilities of connecting the heater, we present selected recommendations which take into account various solutions of the warm utility water system, types of heat sources as well as central heating systems. It is very important to ensure that the process of controlling the individual units of the system is correct as it determines the correctness and efficiency of the system performance.

5.1 Connection of the Utility Water System

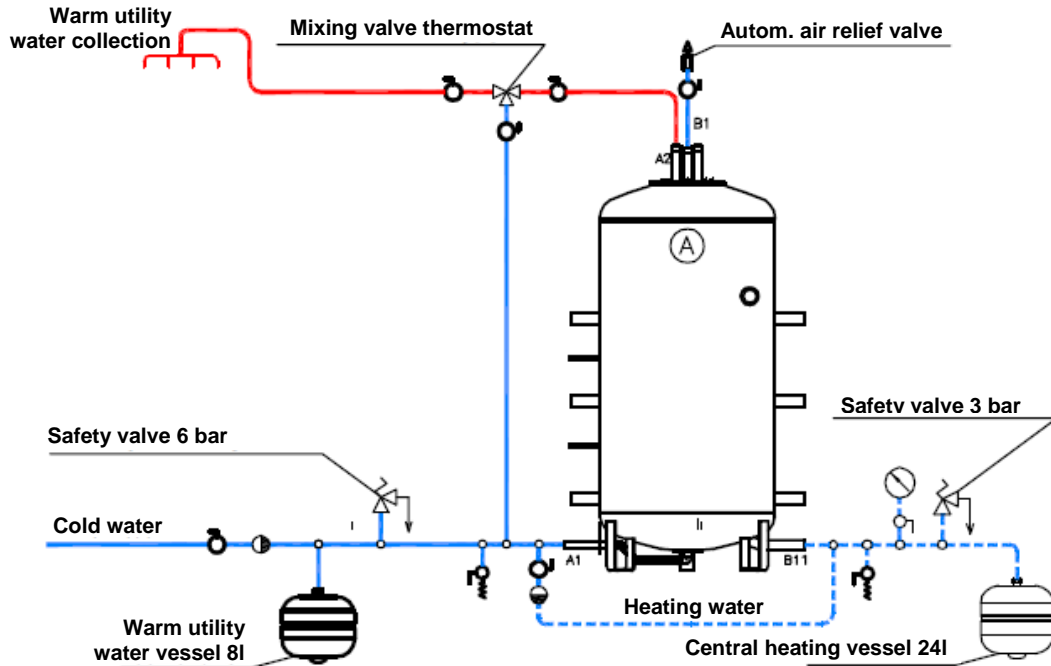

Fig 1. Warm water system without circulation

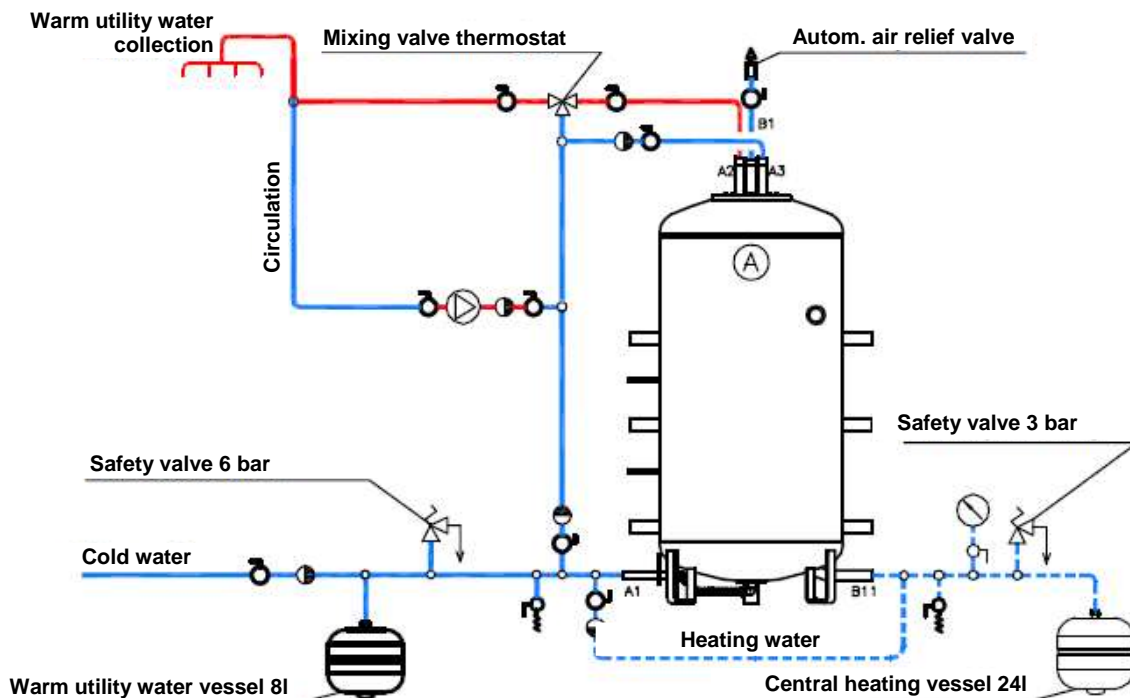

Fig 2. Warm water system with circulation

To keep the warm water temperature stable and also to provide protection against accidental burn, we recommend installing a thermostatic mixing valve. For the warm utility water system with a thermostatic mixing valve and a circulation pump, we recommend a solution, designed by Hewalex, which prevents transferring heat from the upper to the lower part of the heater. This occurs when the utility water outlet temperature is higher than the one pre-set for the mixing valve. If that is the case, the colder water is drawn by the valve from the heater's lower zone while the circulation pump is working. The warm water, returning to the heater through circulation, slowly begins to increase the temperature of lower parts of the heater. This process is prevented as the water is collected to be re-mixed from the circulation and by a system of additional return valves (Fig. 2).

5.1 Connection of the Building Central Heating System

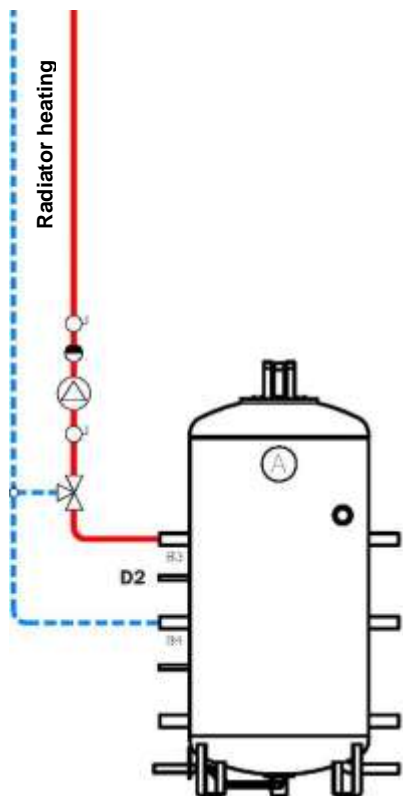

Fig 3. Connecting a heating system with one heating circuit

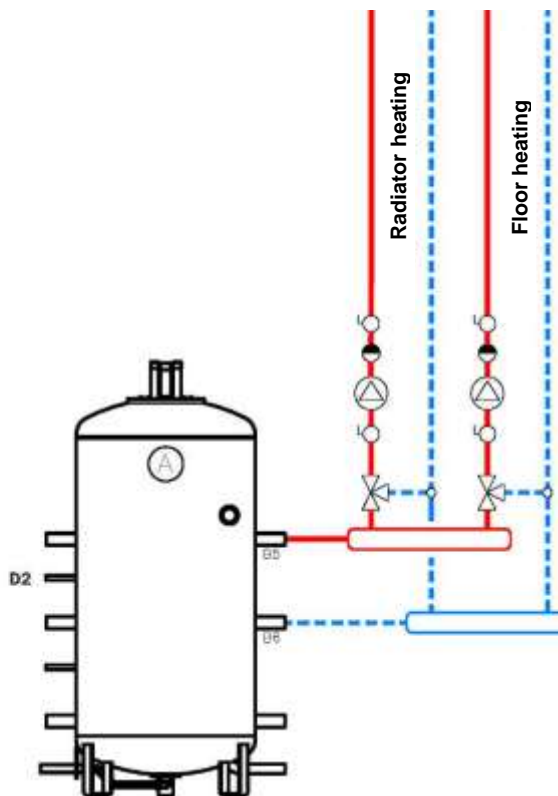

Fig. 4. Connecting a heating system with many heating circuits

The Figures 3 and 4 present the ways of connecting the system to the heater. It is recommended to use mixing valves both in case of a floor heating system and a heater system. Valves should be controlled in accordance with the time of the day, the outdoor temperature and thermal losses of the building (choice of the weather curve).

5.3 Connection of a Gas, Oil and Electric Boiler

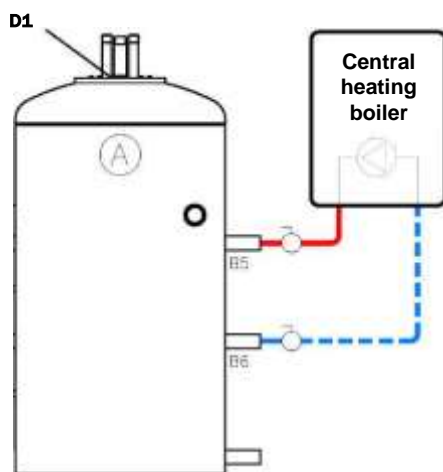

Fig 5. Connecting the boiler for heating the entire middle zone

The best solution is a single-function boiler with a warm water heating function. The boiler sensor for the warm utility water operation mode should be placed in the D1 sleeve situated in the top hatchway of the reservoir. If the water temperature falls below the pre-set one, the boiler increases the operational temperature up to the required level. After achieving the pre-set temperature for warm utility water, the boiler returns to the operational temperature required to heat the building.

5.4 Connection of a Solid Fuel Boiler and a Fireplace with a Water Jacket

In case of boilers which have an efficient power control and low inertia of response to the required temperature change, the connection should be made in a similar way as for e.g. a gas boiler. At the same time, you can install a valve which allows accumulating heat in a greater capacity of the heater (Fig. 6). Fireplaces and boilers with a limited power control range should be connected to the stubs in the lower part of the heater, as it is shown on Fig. 7. While installing a boiler in an open type system, it is required to use a properly chosen heat exchanger.

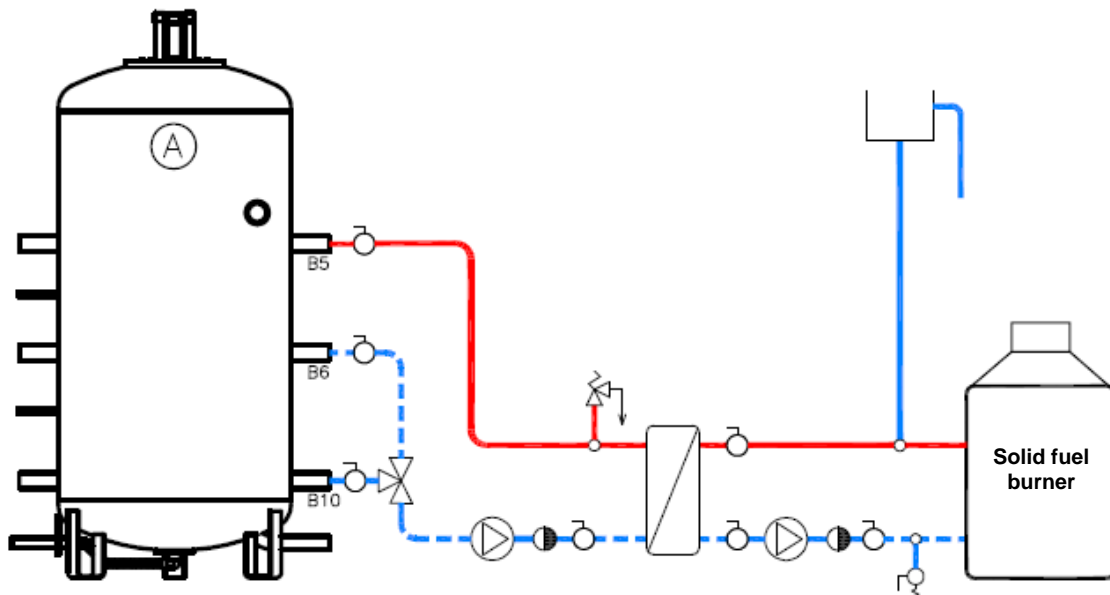

Fig 6. Connection of a slow-burning boiler with power control (e.g. with a feeder or for pellets)

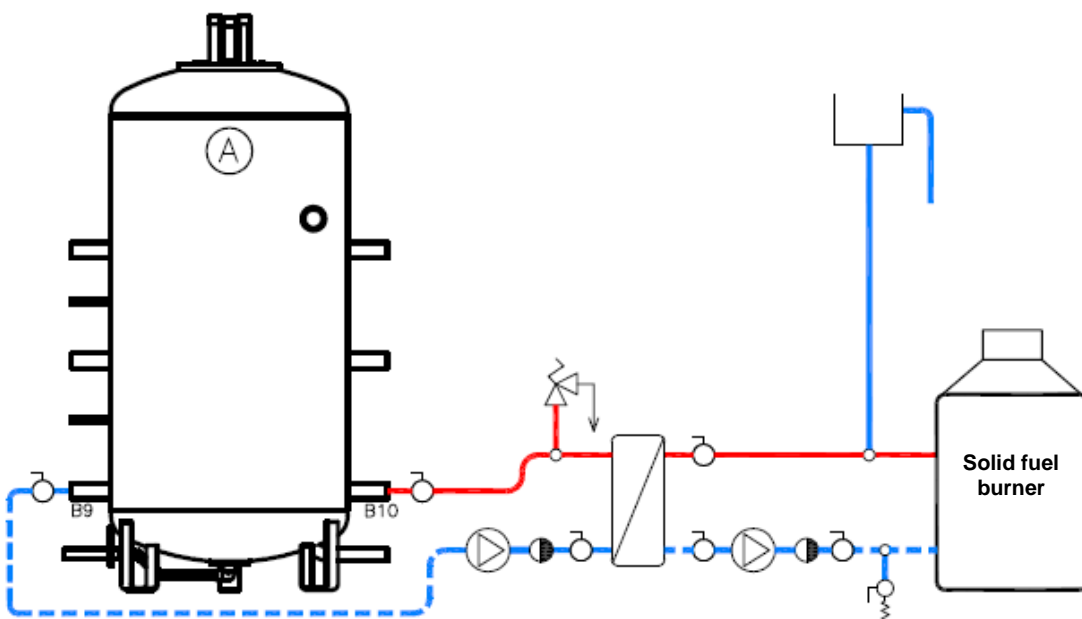

Fig 7. Connection of a boiler or a fireplace with a limited power control range or burning process control range

5.5 Connection of a Heat Pump

Depending on the type and power of the heat pump, choose one of the diagrams presented on Fig 8-10. Remember that, in case of heat pumps, the temperature of the upper source (the heating water supply) is lower and therefore, in case the demand for the warm utility water is higher, it may be necessary to provide e.g. an electric heater supplied with water from the INTEGRA reservoir.

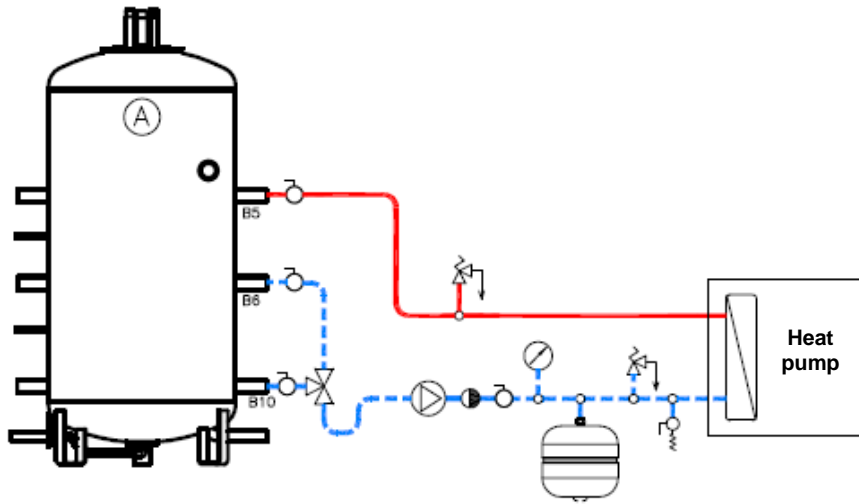

Fig 8. Connection of a ground heat pump

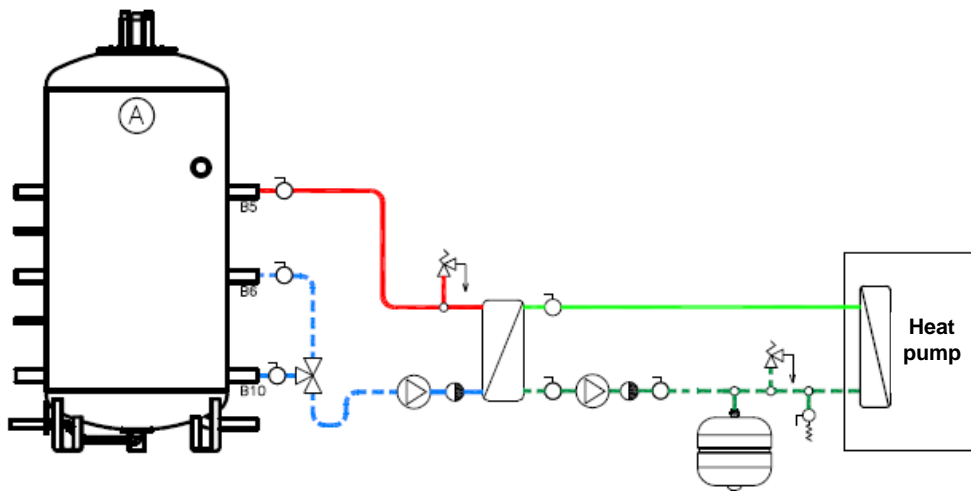

Fig 9. Connection of air heat pump of a greater power

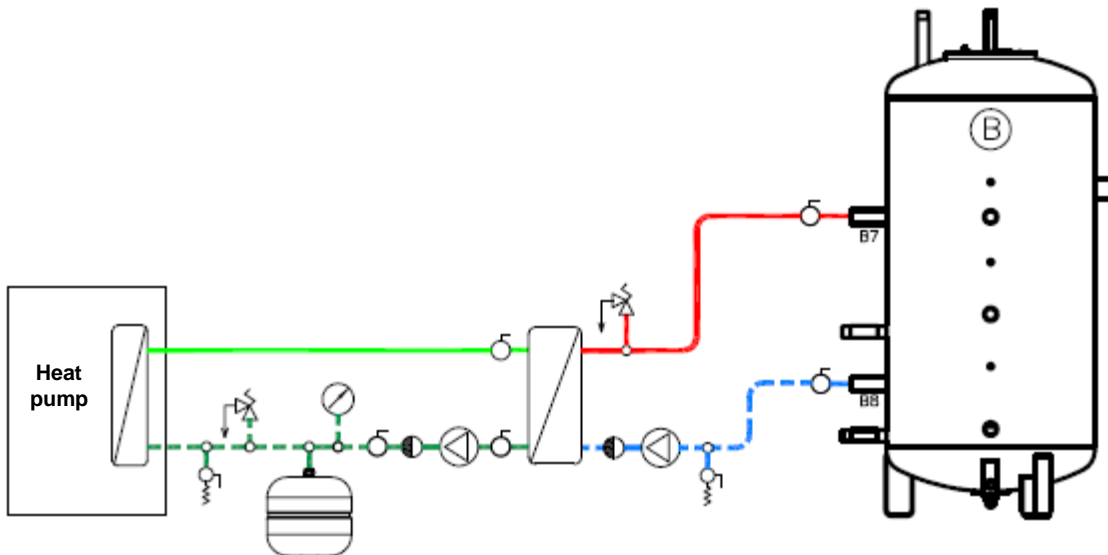

Fig 10. Connection of air heat pump of a lower power

5.6 Connection of Solar Collectors

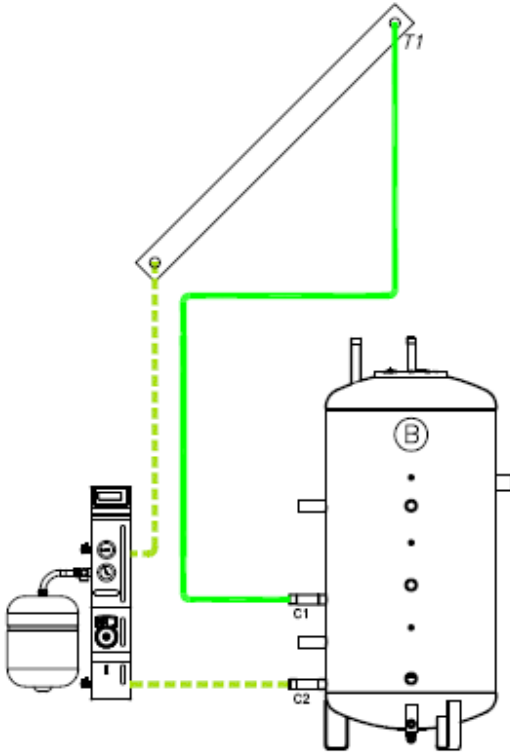

Fig 11. Installation in case when the surface area of the collectors is as specified in Table 1 (page1)

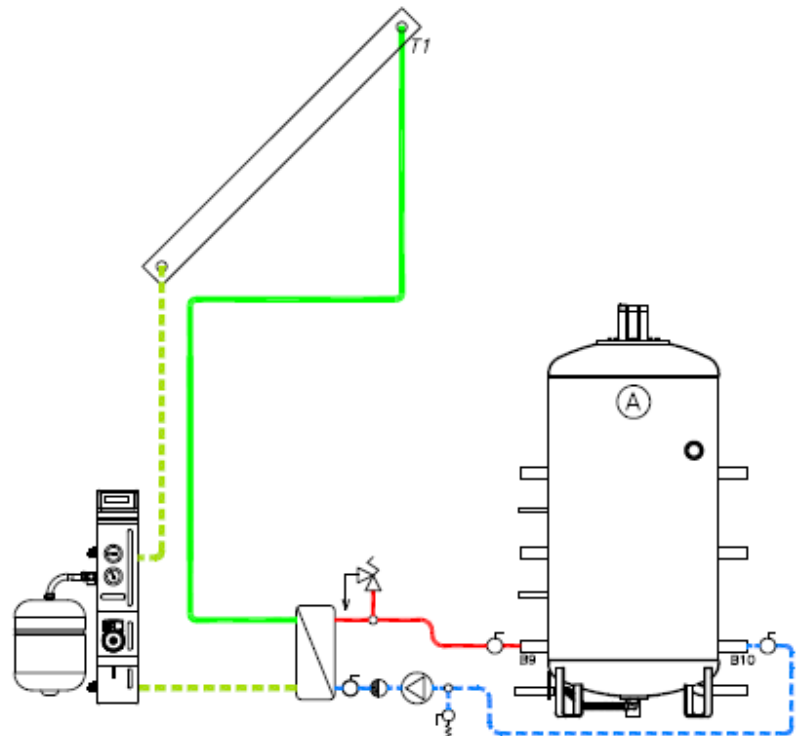
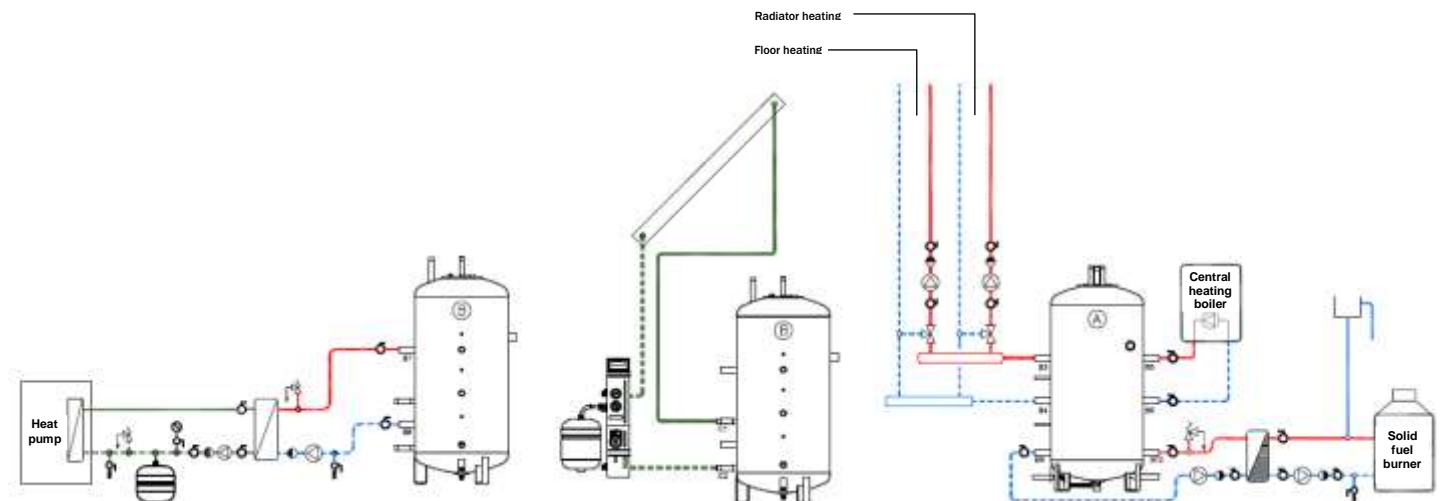

Fig 12. Installation in case when the surface area of the collectors is larger than that specified in Table 1 (page 1)

Considering the nature of the agent which is the non-freezing fluid, connect the solar system to the tubular exchanger in the lower zone of the heater. Depending on the amount of the available solar energy, it will be used not only to heat the utility water but also to support the heating of the building, especially in case of systems including low temperature heating systems.

Exemplary connection of a natural gas boiler, a solid fuel boiler, solar collectors, an air heat pump to a warm utility water and central heating system (the drawings present separately single systems of one complete heating system).



Warranty Card

INTEGRA device name and type

Year of production and serial no

Date of sale

Seller's signature and stamp.....

The purchase receipt or the sale invoice should be attached to the warranty.

The warranty is invalid unless the below items are satisfied.

TERMS OF WARRANTY

1. HEWALEX gives 5-year warranty covering the correct operation of the INTEGRA type indirect heater.
2. The user is entitled to free repairs of damages which occur due to the manufacturer's fault during the warranty period.
3. HEWALEX is relieved of the liability for defective operation of the device which may occur as a result of using it inconsistently with the operation manual, repairing and modifying it by unauthorised persons and other damages which have not occurred due to the manufacturer's fault.
4. Defects which will be revealed during the warranty period will be removed within 30 days from the day when they are reported by the user.
5. Warranty notifications should be sent to the Claim Department of Hewalex Sp. z o.o. Sp.K., ul. Słowackiego 33, 43-502, Czechowice-Dziedzice (tel.+48(32) 214 17 10, GSM: + 48 723 232 232, INFOLINE: 0801 000 810, hewalex.eu).
6. The Buyer is entitled to have the device replaced with a new one or have the costs returned in case when the defect is found to be of a factory origin and irremovable.
7. The warranty rights may be executed only upon presentation of a valid Warranty Card. The Warranty Card which is not filled in or filled in partially, or which bears marks of an interference in its content, is considered invalid.
8. Unjustified visits of the manufacturer's service unit may be the basis for charging the user with costs.
9. The equipment must be stored in dry rooms, free from dust and chemicals aggressive for its materials. The indoor air temperature in the room with the heater should be within the range from +5°C to +45°C and the relative humidity should be up to 80%.
10. Check the condition of the magnesium anode in the installed integrated enamelled warm utility water heater at least once a year and replace it at least every 24 months.
11. Observe the standard requirements with regard to the protection of the heater elements from exceeding the permissible operational specifications. Damages which result from exceeding the operational specifications and the lack of protective elements may not be considered to be the basis for recognising the warranty claims.
12. First, fill up the internal warm utility water reservoir with water and keep it the operational pressure inside it; secondly, fill up the heater with the heating water. If you reverse the filling sequence, the internal reservoir can become damaged in a way which is not covered by the given warranty.

Magnesium anode replacement confirmation	
24 months	
	date, installer's stamp and signature
48 months	
	date, installer's stamp and signature